

Testing of Craft-Bilt Aluminum Decking

Prepared for:

Mr. Bart Bremmers
Craft-Bilt Materials Ltd.
140 Steelcase Road West
Markham, Ontario
L3R 3J9

Trow Associates Inc.

1595 Clark Boulevard
Brampton, Ontario
Telephone: (905) 793-9800
Facsimile: (905) 793-0641

BRBS00144427A
November 24, 2005

Table of Contents

1. Introduction	1
1.1 Description of Tested Decking System.....	1
2. Test Program	1
2.1 Apparatus	1
2.2 Test No. 1.....	2
2.2.1 Description of Test Sample.....	2
2.2.2 Test Procedure and Set-up	2
2.3 Test No. 2.....	2
2.3.1 Description of Test Sample.....	2
2.3.2 Test Procedure and Set-up	2
2.4 Test No. 3.....	2
2.4.1 Description of Test Sample.....	2
2.4.2 Test Procedure and Set-up	2
2.5 Test No. 4.....	3
2.5.1 Description of Test Sample.....	3
2.5.2 Test Procedure and Set-up	3
2.6 Test No. 5.....	3
2.6.1 Description of Test Sample.....	3
2.6.2 Test Procedure and Set-up	3
2.7 Test No. 6.....	3
2.7.1 Description of Test Sample.....	3
2.7.2 Test Procedure and Set-up	3
2.8 Test No. 7.....	4
2.8.1 Description of Test Sample.....	4
2.8.2 Test Procedure and Set-up	4
2.9 Test Results.....	4
3. Conclusions	5

Appendices

Appendix A: Drawings of deck board and starter strip cross sectional profiles

Appendix B: Sketches of test set-ups and loading schematics

1. Introduction

Trow Associates Inc. (Trow) was retained by Craft-Bilt Materials Ltd. (Craft-Bilt) to conduct a load testing program on their extruded aluminum decking.

The testing was performed on July 28 and 29, 2005 by Messrs. Adrian Sluga and Petr Vegh, Ph.D., P.Eng of Trow. All testing was performed at Trow's Structural Testing Laboratory in Brampton, Ontario.

1.1 Description of Tested Decking System

The tested deck boards are made of extruded aluminum with a non-skid textured coating applied to the top surface. An extruded aluminum starter strip is utilized at the long edge of the decking installation. The deck boards are fastened to the deck framing along one longitudinal edge with one #10 wood screw at each joist. The other edge of the deck board locks into the adjacent board to form an interlocked decking system. A drawing that describes the cross sectional profiles of the tested deck board and starter strip is provided in Appendix A.

2. Test Program

A total of seven (7) different tests were performed on the decking. Sketches illustrating the test set-up and loading schematic for each test are provided in Appendix B.

In this section of the report, the general testing apparatus used in all of the tests is described, followed by an explanation of the set-up, procedure, results, and observations for each test performed.

2.1 Apparatus

The apparatus employed to conduct the static load tests consisted of a steel reaction frame, hydraulic cylinder, hydraulic hand pump and an S-type load cell. A Power Team, model RD256, double-acting, 25 ton capacity hydraulic cylinder as manufactured by the Owatonna Tool Company was used to apply the load. The cylinder was actuated with an Enerpac hand pump. The load was transferred through a Sensotech, model 20210-20K, S-Type, 20,000 lbf (90 kN) capacity load cell and continuously monitored with a digital process indicator. For test number 7, the vertical deflection of the decking boards was monitored using a Mitutoyo Digital Indicator.

All tests were performed on a mock-up pressure treated wood deck built by Craft-Bilt. The deck framing consisted of (4) 38x184 (2 x 8) joists @ 610 mm (24") on centre. A 38x184 (2 x 8) rim board was nailed to one end of joists. The decking boards were installed perpendicular to the joists in all of the tests.

2.2 Test No. 1

2.2.1 Description of Test Sample

The tested decking sample consisted of four decking boards and one starter strip that continuously spanned over four joists.

2.2.2 Test Procedure and Set-up

A downward transverse line load was applied at mid-span of the decking between the first and second joist from the end of the deck (i.e. end span). The load was transferred through a steel spreader beam resting on a 38 x 140 (2 x 6) wood member oriented perpendicular to the decking boards.

2.3 Test No. 2

2.3.1 Description of Test Sample

The tested decking sample consisted of four decking boards and one starter strip that continuously spanned over four joists.

2.3.2 Test Procedure and Set-up

A downward transverse line load was concurrently applied midway between the first two joists from the edge (i.e. end span) and midway between the next two joists (i.e. intermediate span). This was accomplished by applying the load through a steel spreader beam oriented parallel to the decking boards into a 38 x 89 (2 x 4) member aligned perpendicular to the deck boards at each end of the beam.

2.4 Test No. 3

2.4.1 Description of Test Sample

The tested decking sample consisted of four decking boards and one starter strip that continuously spanned over four joists.

2.4.2 Test Procedure and Set-up

A downward concentrated load was applied at mid-span between the first and second joist to the second plank from the edge. The load was transferred into the deck using a 25.4 mm (1") diameter steel rod to simulate loading from items placed on the deck such as a chair.

2.5 Test No. 4

2.5.1 Description of Test Sample

The tested decking sample consisted of one deck board and one starter strip that continuously spanned over four joists.

2.5.2 Test Procedure and Set-up

A downward transverse line load was applied at mid-span of the deck board between the first and second joist from the end of the deck (i.e. end span). The load was transferred through a steel spreader beam resting on a 38 x 140 (2 x 6) wood member oriented perpendicular to the deck board.

2.6 Test No. 5

2.6.1 Description of Test Sample

The tested decking sample consisted of one unscrewed deck board resting right side up on top of the framing that continuously spanned over four joists.

2.6.2 Test Procedure and Set-up

A downward transverse line load was applied at mid-span of the deck board between the first and second joist from the end of the deck (i.e. end span). The load was transferred through a steel spreader beam resting on a 38 x 140 (2 x 6) wood member oriented perpendicular to the deck board.

2.7 Test No. 6

2.7.1 Description of Test Sample

The tested decking sample consisted of one unscrewed deck board resting upside down on top of the framing that continuously spanned over four joists.

2.7.2 Test Procedure and Set-up

A downward transverse line load was applied at mid-span of the deck board between the first and second joist from the end of the deck (i.e. end span). The load was transferred through a steel spreader beam resting on a 38 x 140 (2 x 6) wood member oriented perpendicular to the deck board.

2.8 Test No. 7

2.8.1 Description of Test Sample

The tested decking sample consisted of four decking boards and one starter strip that continuously spanned over four joists.

2.8.2 Test Procedure and Set-up

A downward transverse line load was applied at mid-span of the decking between the first and second joist from the end of the deck (i.e. end span). The load was transferred through a steel spreader beam resting on a 38 x 89 (2 x 4) wood member oriented perpendicular to the decking boards. The vertical mid-span deflection of the decking board was monitored during this test.

2.9 Test Results

The results and observations for each test are summarized in Table 2.8 below. For test numbers 1, 2, 4, 5, 6 and 7 the corresponding uniformly distributed load is given in the table. This load was calculated to generate the same bending moment as the line load applied in the test.

Table 2.8: Summary of Test Results

Test No.	Maximum Load Applied (kN) [lbf]	Corresponding Uniformly Distributed Load (kPa) [psf]	Observations
1	9.72 [2186]	52.1 [1085]	After releasing the load, no visible signs of distress or failure resulting from the applied load were observed.
2	9.79 [2201]	19.7 [410]	After releasing the load, no visible signs of distress or failure resulting from the applied load were observed.
3	9.31 [2093] (concentrated load)	N/A	Localized displacement of decking observed at the point of load application. After releasing the load, some permanent deformation was observed.
4	6.22 [1398]	134.2 [2796]	After releasing the load, no visible signs of distress or failure resulting from the applied load were observed.
5	4.96 [1115]	107 [2229]	Load could not be increased beyond 4.96 kN as deck board had yielded in flexure and continued to deflect. After releasing the load, minimal permanent deformation was observed.

Test No.	Maximum Load Applied (kN) [lbf]	Corresponding Uniformly Distributed Load (kPa) [psf]	Observations
6	4.58 [1029]	98.8 [2058]	Load could not be increased beyond 4.58 kN as deck board had yielded in flexure and continued to deflect. After releasing the load, minimal permanent deformation was observed.
7	0.92 [207]	4.8 [100]	Midspan deflection of the decking boards was measured to be 1.9 mm. This deflection is equivalent to $L/301$ where L is the clear span between the joists = $610 - 38 = 572$ mm

The results from test numbers 5 and 6 were used to establish the bending moment capacity of a single unscrewed deck board for bending in both directions. The yield bending moment capacities were calculated to be 0.76 kN.m for a point load applied to the board oriented right side up and 0.70 kN.m for a point load applied to the board oriented upside down.

3. Conclusions

Based on the results of the aluminum decking test program as described in this report, the following conclusions can be made:

- The tested decking system can support a line load of 9.72 kN applied at midspan without failure. The corresponding uniformly distributed load that would generate the same bending moment as this line load was calculated to be 52.1 kPa.
- The tested decking system can support a concentrated load of 9.31 kN applied at midspan without failure.
- The yield bending moment capacities of a single deck board were calculated to be 0.76 kN.m for a point load applied to the board oriented right side up and 0.70 kN.m for a point load applied to the board oriented upside down.
- The tested decking sample was measured to deflect 1.9 mm under a line load applied at midspan that would produce the same bending moment as a 4.8 kPa (100 psf) uniformly distributed load.

We trust the above is satisfactory. Should you have any questions or comments, please do not hesitate to contact the undersigned.

Yours truly,

Trow Associates Inc.

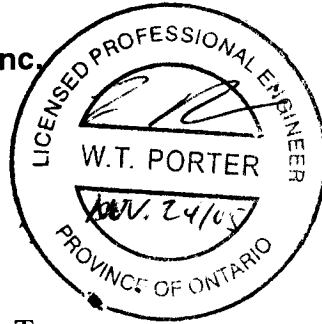

Todd Porter, P.Eng.
Project Engineer
Building Engineering Team

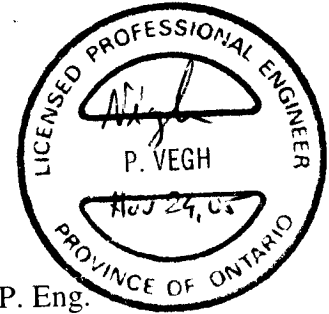

Petr Vekh, Ph.D., P. Eng.
Senior Project Manager
Building Engineering Team

APPENDIX A
Drawing of deck board and starter strip
cross sectional profiles

CUSTOMER	CRAFTBILT	PART NO.	-	DIE NO.	AS-50976	DASH	1
DESCRIPTION:	DECK "F" CHANNEL	TARRIF#	7604.29.10.00	PROPOSAL#	11531-3B		
INDALEX LIMITED 5675 Kennedy Road Mississauga, Ontario L4Z 2H9		DATE	SYM	REVISION			

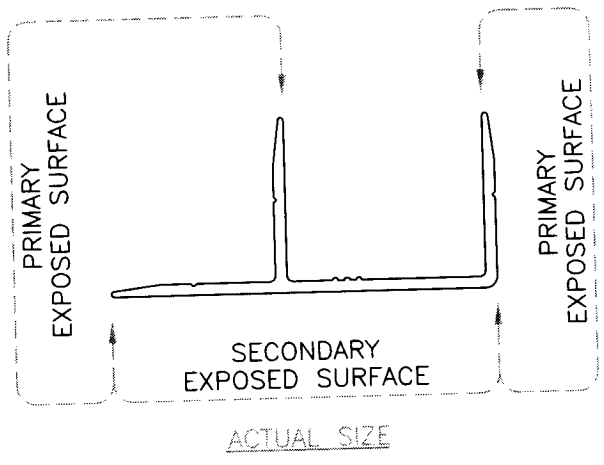
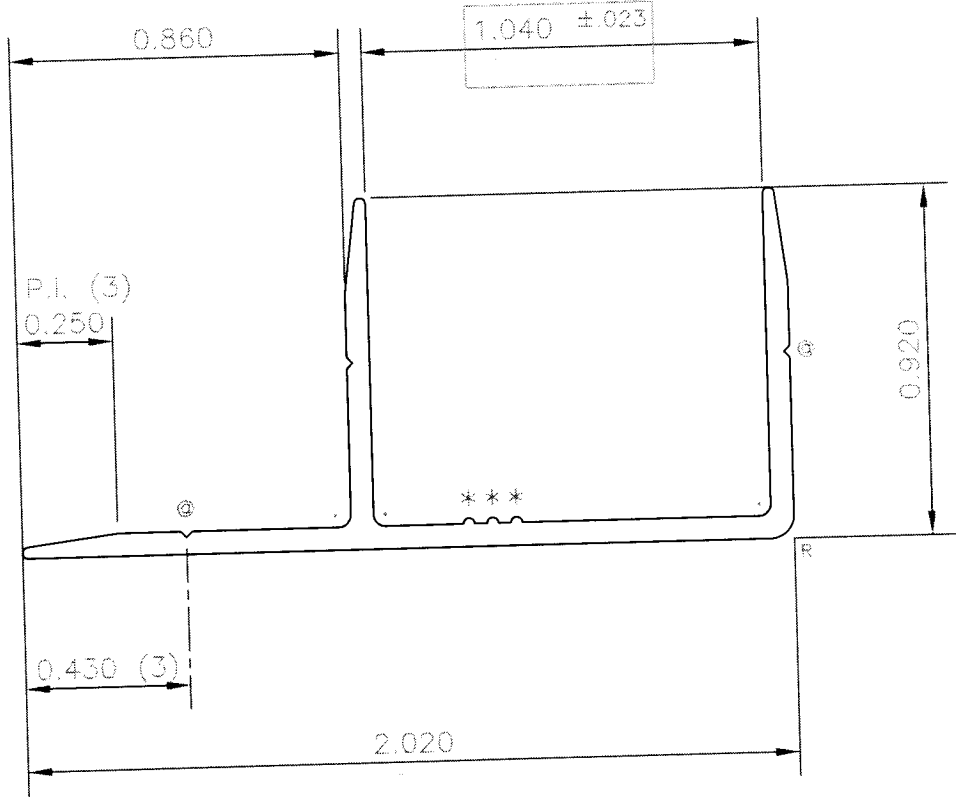

(*) = 0.010(0.25) R. X 0.010(0.25)H. INDALEX I.D. MARKS

(C) = 0.015(0.38)D. X 90° (3)
 (D) = 0.031(0.79) R. (4)
 (R) = 0.062(1.72) R. (1)
 BREAK CORNERS = 0.015(0.38) R.

 INDALEX ALUMINUM SOLUTIONS	UNSPECIFIED WALL THICKNESS		
	0.060(1.52)		
EST. AREA	0.213 IN ² 137 MM ²	OUT PER.	- IN - MM
EST. WT.	0.255 LBS/FT. 0.380 KG/M	FACTOR	29
EST. PER.	7.487 IN 190 MM	C.C.D.	2.189 IN 56 MM
DWN BY	J.S.	ALLOY	6063-T5
		SCALE	2:1
		DATE	05/01/04

BREAK ALL CORNERS 0.10"R (0.25R) UNLESS OTHERWISE NOTED

STANDARD ALUMINUM ASSOCIATION TOLERANCES TO APPLY UNLESS OTHERWISE SPECIFIED

CUSTOMER		CRAFTBILT		PART NO.		DIE NO.		DASH	
INDALEX LIMITED 5675 Kennedy Road Mississauga, Ontario L4Z 2H9		DECK-BOARD		AS-50968		2			
DESCRIPTION:		TARIFF# 7604.29.10.00		PROPOSAL# 11531-1A					
		DATE		REVISION		BY			
		06/04/04		.925 WAS .930; 7.162 WAS 7.165		[EB]			
		05/04/04		.222 WAS .225; .160 WAS .170; RECALC		[G.S.]			

EXPOSED SURFACE

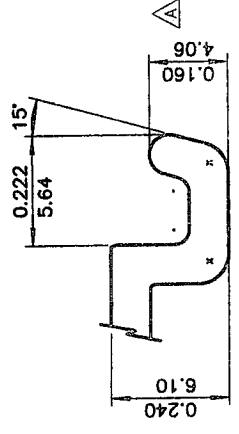
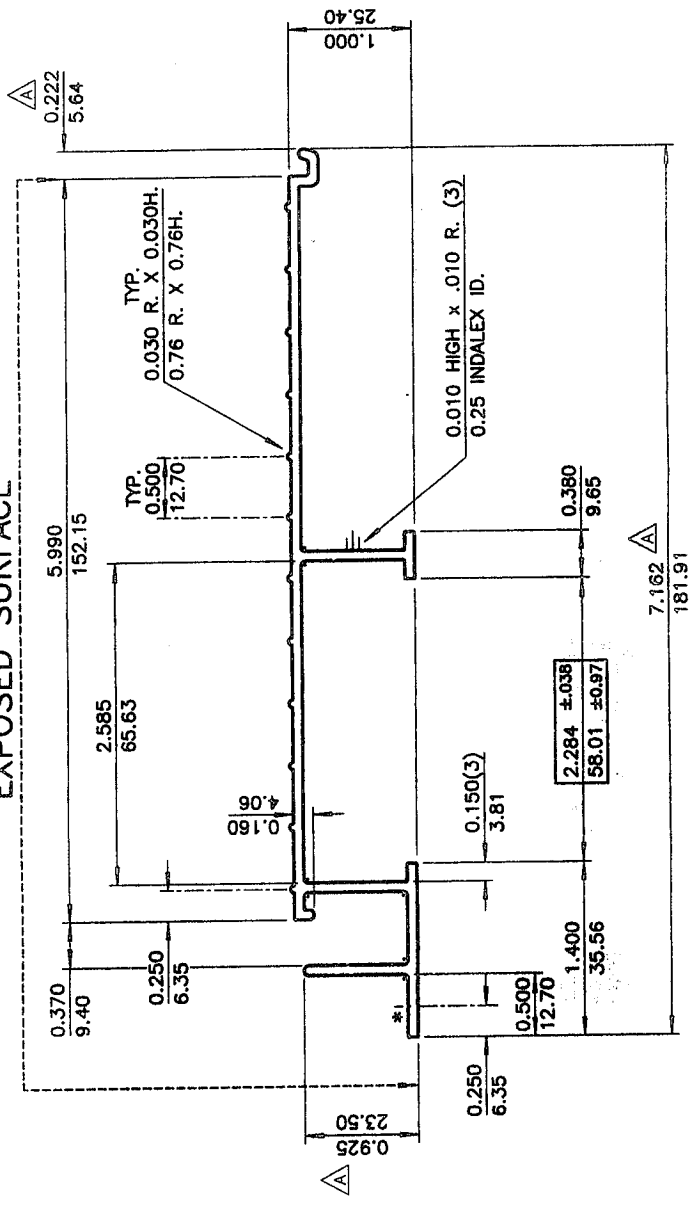

DETAIL 4:1

NOTE:
TO MATE WITH SELF

(*) = 0.010(0.25)D. X 90° (1)
() = 0.031(0.79) R. (9)
(*) = 0.062(1.57) R. (2)
UNMARKED RADII = RADIUS TO SUIT

INDALEX ALUMINUM SOLUTIONS		UNSPECTED WALL THICKNESS	
0.080(2.03)			
EST. AREA	0.881 in ² 568 mm ²	OUT PER.	— IN — MM
EST. WT.	1.036 LBS/FT. 1.542 KG/M	FACTOR	21
EST. PER.	21.929 IN 557 MM	C.C.D.	7.206 IN 183 MM
DWN BY	J.S.	ALLOY	6005-T6
SCALE	1:1	DATE	05/01/04
BREAK ALL CORNERS .010" R. (0.254) UNLESS OTHERWISE NOTED.			
SAMPLE APPROVAL		SIGNED: <i>Jay...</i>	
THIS SAMPLE IS APPROVED AND INDALEX LIMITED MAY PROCEED WITH PRODUCTION		DATE:	
STANDARD ALUMINUM ASSOCIATION TOLERANCES TO APPLY UNLESS OTHERWISE SPECIFIED			

APPENDIX B

Sketches of test set-ups and loading schematics



PROJECT NAME
Craft-Bilt Materials Ltd.
Aluminum Decking Tests

SUBJECT
Set-up and Loading schematic
for Test No. 1

BY	PROJECT NO. BRBS00144427A
APPRVD.	PAGE OF
DATE	CALC. NO.

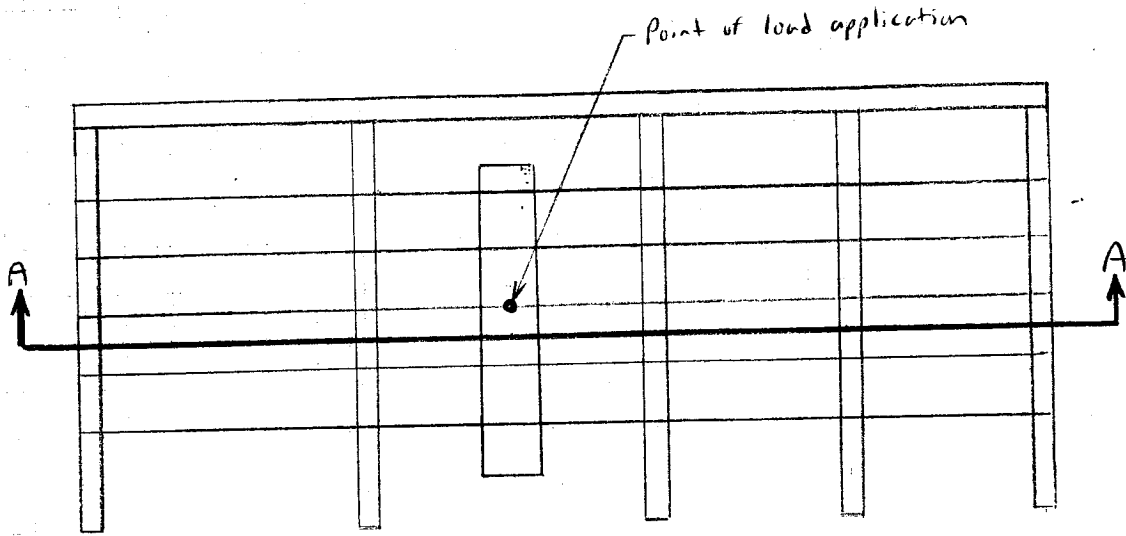

PLAN VIEW
N.T.S.

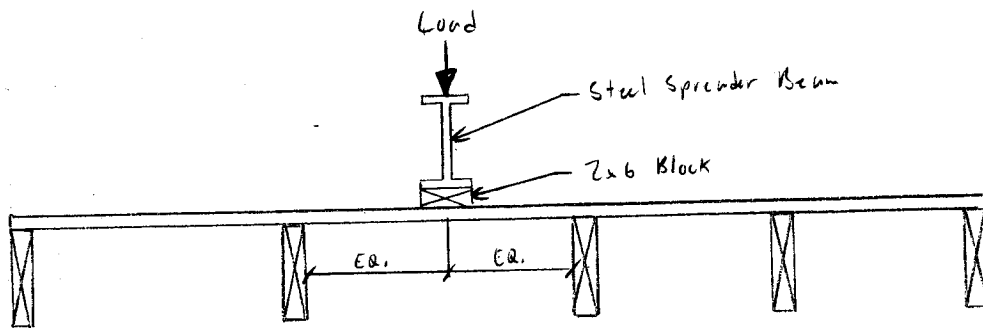

SECTION AA
N.T.S.



PROJECT NAME
Craft-Kilt Materials Ltd.
Aluminum Decking Tests

SUBJECT
Set-up and Loading schematic
for Test No. 2

BY	PROJECT NO.
APPRVD.	PAGE OF
DATE	CALC. NO.

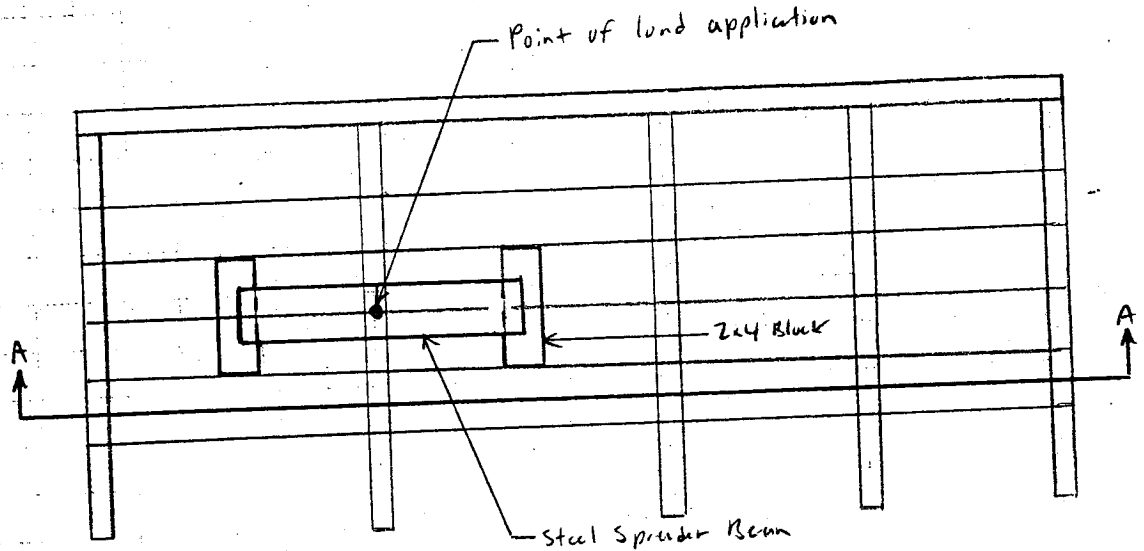

PLAN VIEW
N.T.S.

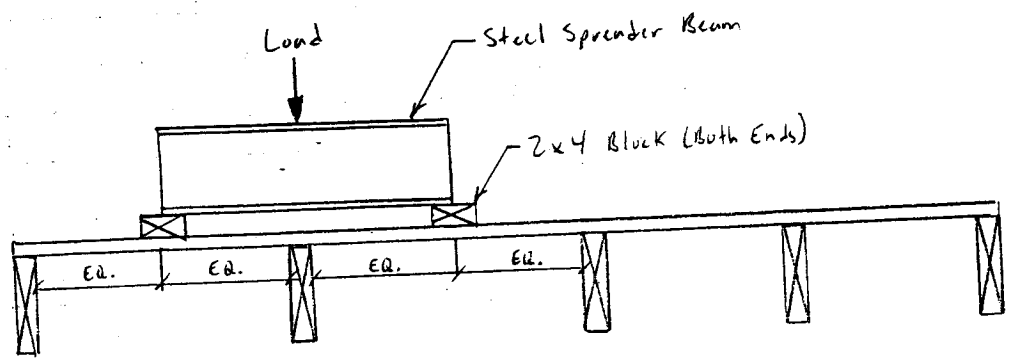

SECTION AA
N.T.S.



PROJECT NAME
Craft-Kilt Materials Ltd.
Aluminum Decking Tests

SUBJECT
Set-up and Loading schematic
for Test No. 3

BY	PROJECT NO. BRKS0014427A
APPRVD.	PAGE OF
DATE	CALC. NO.

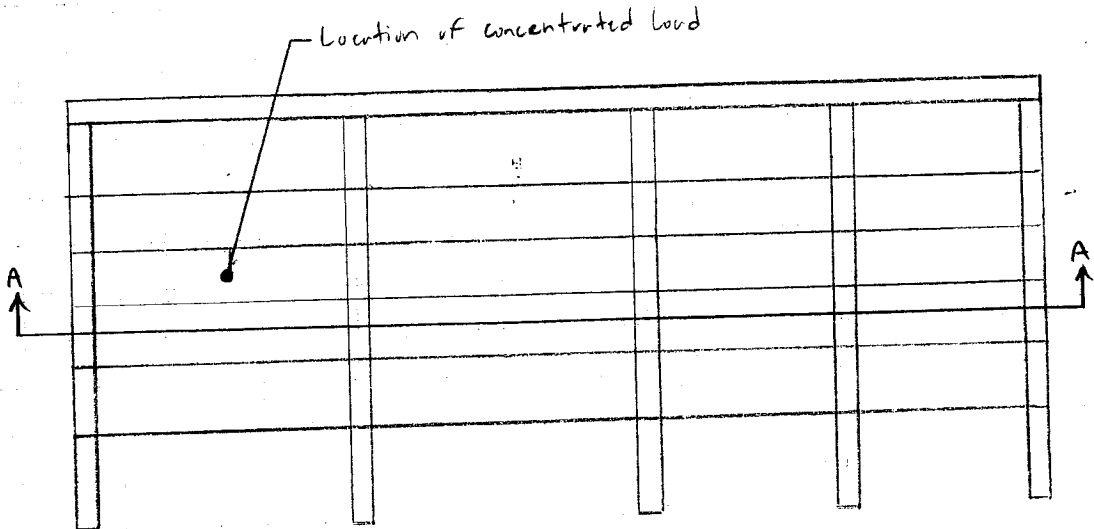

PLAN VIEW
N.T.S.

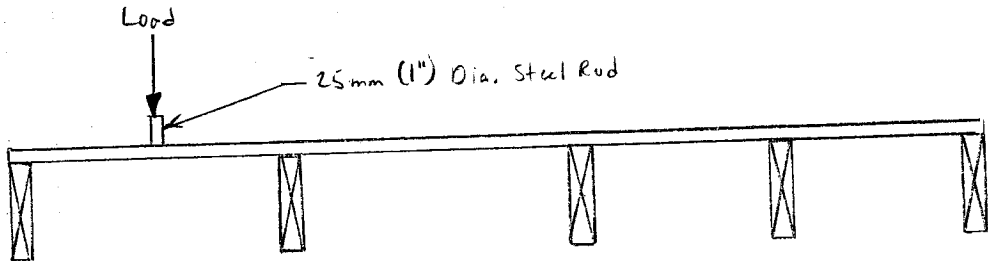

SECTION AA
N.T.S.



PROJECT NAME
Craft-Bilt Materials Ltd.
Aluminum Decking Tests

SUBJECT
Set-up and Loading schematic
for Test No. 4

BY	PROJECT NO. BRBS00144423A
APPRVD.	PAGE OF
DATE	CALC. NO.

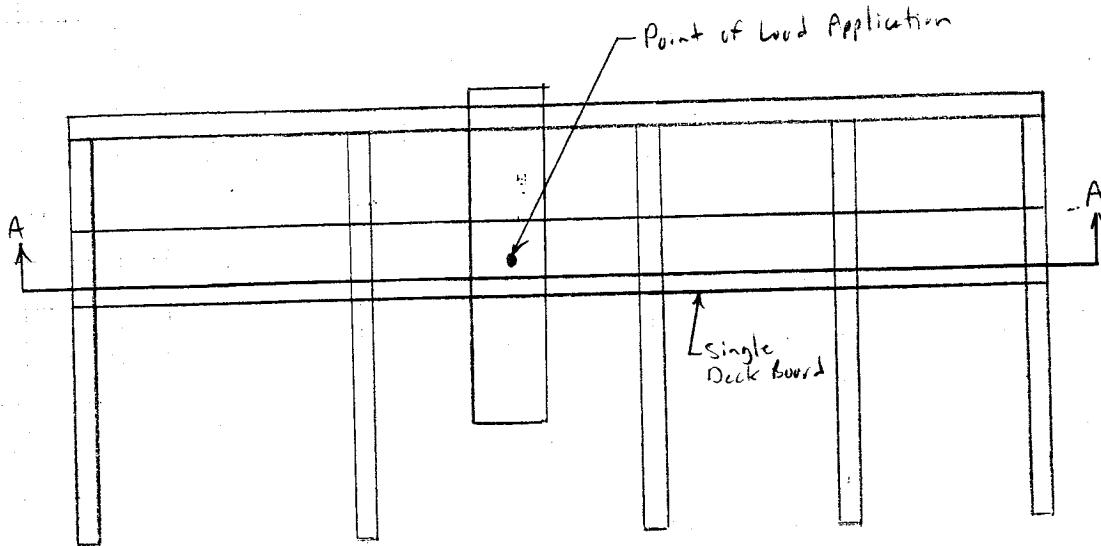

PLAN VIEW
N.T.S.

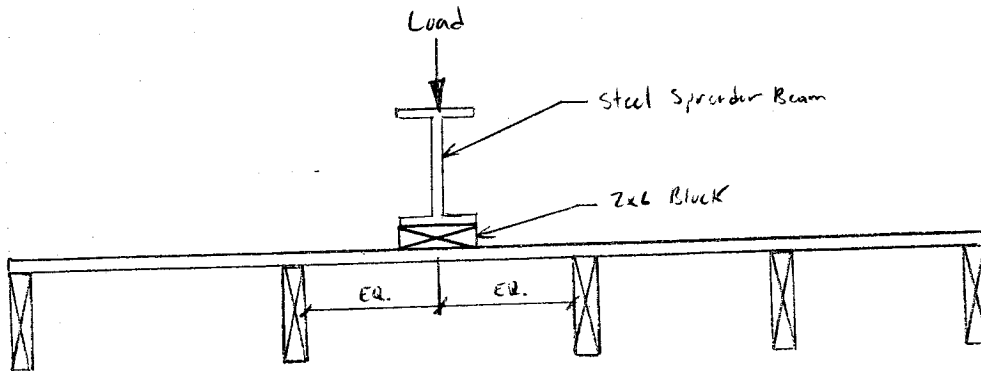

SECTION AA
N.T.S.



PROJECT NAME
Craft-Kitt Materials Ltd.
Aluminum Decking Tests

SUBJECT
Set-up and Loading schematic
for Test Nos. 5 and 6

BY	PROJECT NO. BRKS 00144427A
APPRVD.	PAGE OF
DATE	CALC. NO.

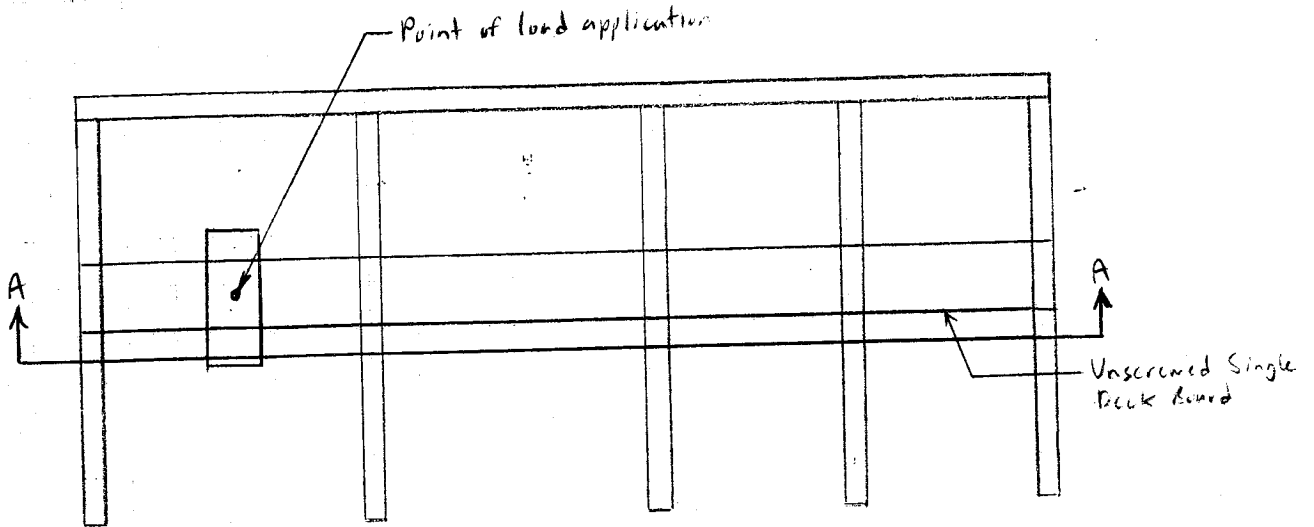

PLAN VIEW
N.T.S.

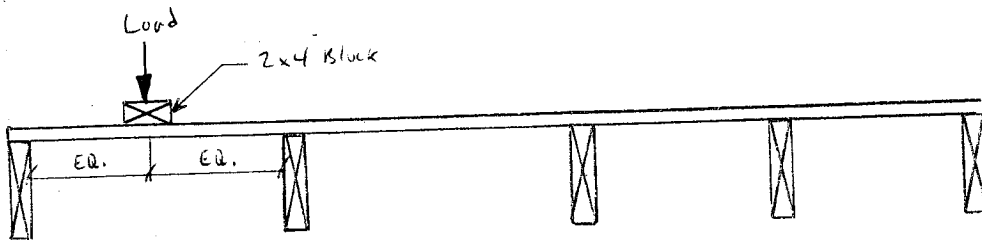

SECTION AA
N.T.S.

Note: Deck board was placed right side up for Test No. 5 and upside down for Test No. 6.